



WINDS SUITE



BOOST

Cv INTERNATIONAL



SUPPLY



BOOST



BOTTLE



SERVICE

BOOSTER

PN: 410111

N-SERIES

Boost Your Efficiency with the Dive Mate BK 12.2!

The **Dive Mate Booster BK 12.2** with inlet regulator takes your nitrogen to the next level, **boosting pressure up to 5000 psig** for fast, efficient fills at the containment station. Need to refill those **88 SCFM nitrogen cylinders** for your **WindKit servicing system**? No problem! With precision and reliability, you'll have them safely refilled to **4500 psig** in **under 10 minutes**—keeping your turbines spinning and your downtime at a minimum!



www.cvintl.com





MODEL: N-SERIES

PART NUMBER: 410111

Why Choose the N-Series Dive Mate Booster?

- **Ultra-Fast Nitrogen Fills:** Boosts nitrogen pressure up to **5000 psig**, refilling **88 SCFM** cylinders to **4500 psig** in **under 10 minutes**, drastically reducing downtime.
- **Precision & Reliability:** Delivers consistent, high-pressure performance with an inlet regulator for safe, accurate nitrogen servicing every time.
- **Built for the Field:** Rugged design, perfectly suited for wind turbine maintenance in even the most challenging environments.
- **Maximize Efficiency & Safety:** Integrates seamlessly with the WindSuite system, streamlining operations while enhancing technician safety at elevation.

WINDSUITE

ACTIONS

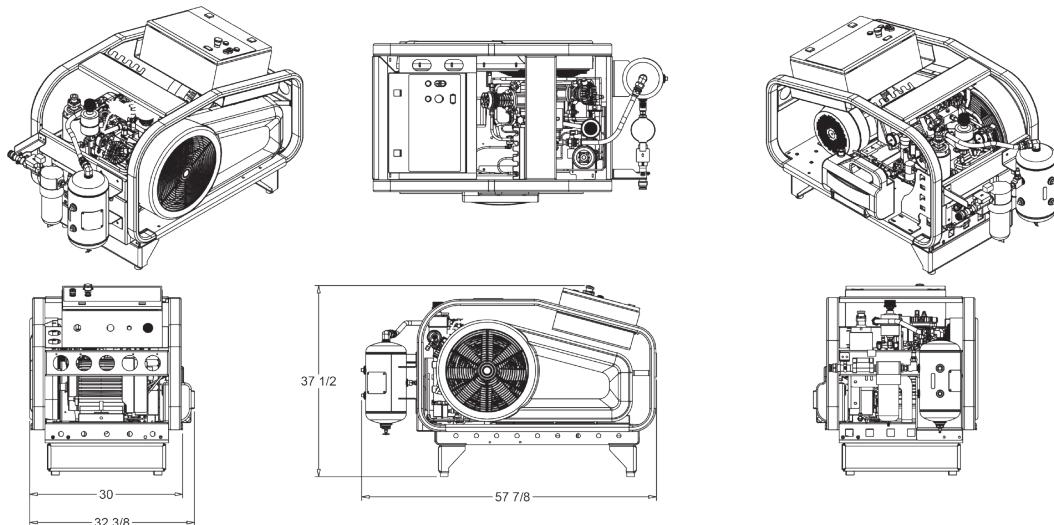
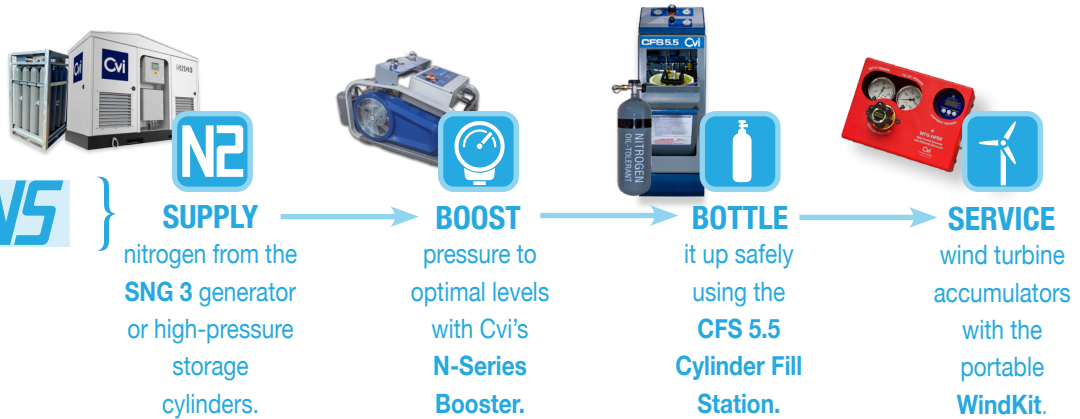

PART NUMBER: 410111



VOSB
VETERAN OWNED SMALL BUSINESS